

# hens

## HS 260

**: product card**



The hens collection is characterised by Scandinavian design and functionality. It adheres to the principles of simplicity, usability and naturalness. The strong steel frame gives the chairs a loft character. Their raw form is balanced by the natural oak veneer and soft upholstery.

**design:**  
**Henrik Schultz**

**Product website**  
[website link](#)



# bejot:

# collection advantages

## scandinavian design and functionality

The collection is a contemporary interpretation of the classic school chair. Designed with inspiration from Scandinavian design, it meets the objectives of simplicity, functionality and naturalness.

## easy stacking

The chairs are perfectly stackable, and some models can be joined together with a dedicated rail. This makes them suitable for virtually anywhere - from offices to schools and public spaces.

## practical armrests

The round cover (PUT) on the armrests is not only an aesthetic finish but also a functional solution that allows for the safe suspension of chairs on the table top. This facilitates keeping floors clean in conference rooms, canteens, and other spaces.

## technical data

HS 260

Standard ●  
Option ○

### Base

Powder painted (colors according to the Bejot sampler) ●

### Castors

### CODE

Hard castors for soft floors Ø 65 with auto-brake ●

DEMA ●

Soft castors for hard floors Ø 65 with auto-brake ○

DEMAD ○

Universal castors without brake, color white ○

RL W4 ○

### Description

### Code

Seat and backrest, natural oak veneer

1N

Upholstered seat / backrest, natural oak veneer

2N

Upholstered seat and backrest

4N

# dimensions

## HS 260

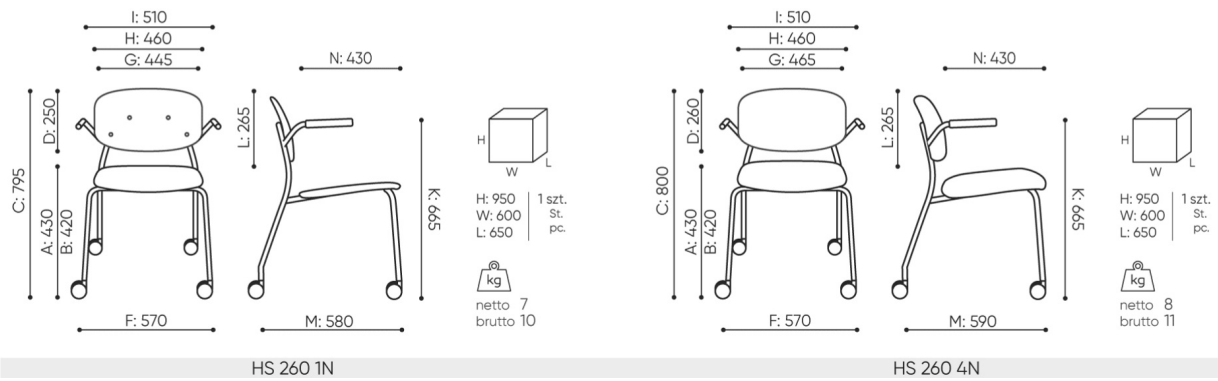

- A seat height: overall dimensions
- B seat height: measured according to the norm  
PN EN 1335 - 1
- C chair height
- D backrest height
- E headrest height
- F dimensional width chair / base
- G seat width
- H backrest width
- I width between armrests
- K height from the floor to the armrest
- L backrest length
- M dimensional chair depth
- N seat depth / seat length

Dimensions are approximate and may vary depending on the selected product configuration. The requirements of the standard are always met.

## materials available for collection

1st price group	Bond, Fenno, Keimo, Sawana
2nd price group	Alaska, Alpa, Charles, Charles - Studio Design, Cura, Era - Studio Design, Pastel, Roccia
3rd price group	Ally, Ally SD, Alpa-Studio Design, Blazer, Cura SD, Cyber SD, Oceanic, Rhythm, Silvertex , Silvertex - Studio Design, Synergy, Synergy - Studio Design
4th price group	Heritage, Oceanic-Studio Design, Remix - Studio Design
5th price group	Accessoire*, Steelcut Trio 3
Leather	Leather
Natural oak veneer	Natural oak veneer
Metal	Metal - powder coated

bejot:hens

